

### FEATURES

- Excellent  $TCV_{OS}$  Match:  $2 \mu V/^{\circ}C$  Max
- Low Input Offset Voltage:  $150 \mu V$  Max
- Low Supply Current:  $100 \mu A$
- Single-Supply Operation:  $5 V$  to  $30 V$
- Low Input Offset Voltage Drift:  $0.75 \mu V/^{\circ}C$  Max
- High Open-Loop Gain:  $2,000 V/mV$
- High PSRR:  $3 \mu V/V$
- Low Input Bias Current:  $12 nA$
- Wide Common-Mode Voltage Range:  $V-$  to Within  $1.5 V$  of  $V+$
- Pin Compatible with 1458, LM158, and LM2904
- Available in Die Form

### GENERAL DESCRIPTION

The OP220 is a monolithic dual operational amplifier that can be used either in single or dual supply operation. The low offset voltage and input offset voltage tracking as low as  $1.0 \mu V/^{\circ}C$ , make this the first micropower precision dual operational amplifier.

The excellent specifications of the individual amplifiers combined with the tight matching and temperature tracking between channels provides high performance in instrumentation amplifier designs. The individual amplifiers feature extremely low input offset voltage, low offset voltage drift, low noise voltage, and low bias current. They are fully compensated and protected.

Matching between channels is provided on all critical parameters including input offset voltage, tracking of offset voltage versus temperature, noninverting bias currents, and common-mode rejection ratios.

### PIN CONFIGURATIONS

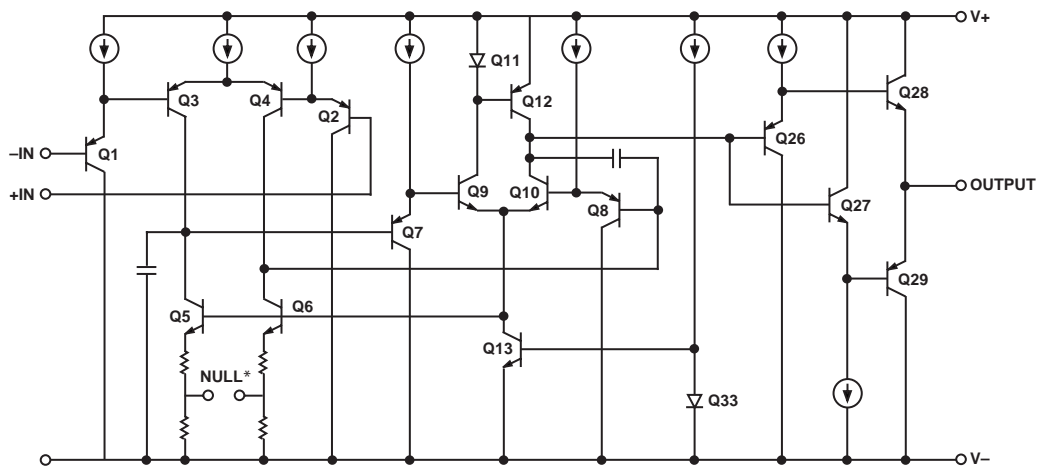
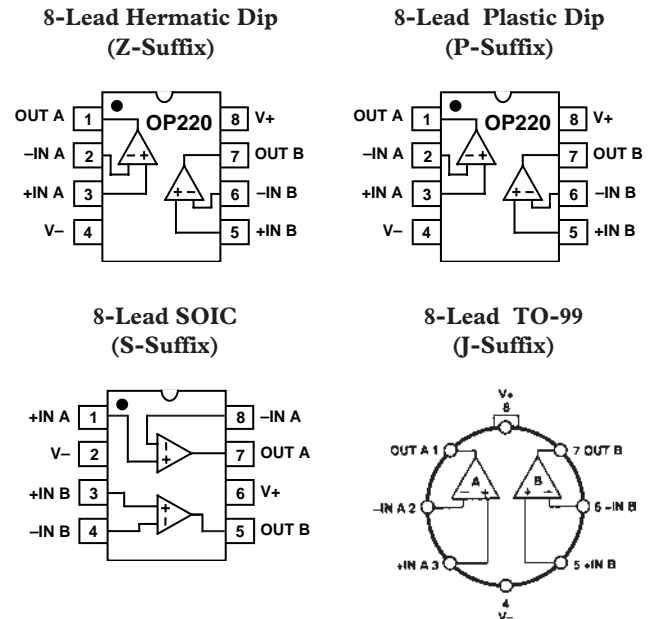

\*ACCESSIBLE IN CHIP FORM ONLY

REV. A

Figure 1. Simplified Schematic

Information furnished by Analog Devices is believed to be accurate and reliable. However, no responsibility is assumed by Analog Devices for its use, nor for any infringements of patents or other rights of third parties that may result from its use. No license is granted by implication or otherwise under any patent or patent rights of Analog Devices.

# OP220–SPECIFICATIONS

## ELECTRICAL CHARACTERISTICS (@ $V_S = \pm 2.5\text{ V}$ to $\pm 15\text{ V}$ , $T_A = 25^\circ\text{C}$ , unless otherwise noted.)

Parameter	Symbol	Conditions	OP220A/E			OP220F			OP220C/G			Unit
			Min	Typ	Max	Min	Typ	Max	Min	Typ	Max	
Input Offset Voltage	$V_{OS}$	$V_S = \pm 2.5\text{ V}$ to $\pm 15\text{ V}$		120	150		250	300		500	750	$\mu\text{V}$
Input Offset Current	$I_{OS}$	$V_{CM} = 0$		0.15	1.5		0.2	2		0.2	3.5	nA
Input Bias Current	$I_B$	$V_{CM} = 0$		12	20		13	25		14	30	nA
Input Voltage Range	IVR	$V_+ = 5\text{ V}$ , $V_- = 0\text{ V}$ $V_S = \pm 15\text{ V}$	0/3.5 -15/+13.5			0/3.5 -15/+13.5			0/3.5 -15/+13.5			V V
Common-Mode Rejection Ratio	CMRR	$V_+ = 5\text{ V}$ , $V_- = 0\text{ V}$ $0\text{ V} \leq V_{CM} \leq 3.5\text{ V}$ $V_S = \pm 15\text{ V}$ $-15\text{ V} \leq V_{CM} \leq +13.5\text{ V}$	90	100		85	90		75	85		dB
			95	100		90	95		80	90		dB
Power Supply Rejection Ratio	PSRR	$V_S = \pm 2.5\text{ V}$ to $\pm 15\text{ V}$ , $V_- = 0\text{ V}$ , $V_+ = 5\text{ V}$ to $30\text{ V}$	3	10		10	32		32	100		$\mu\text{V/V}$ $\mu\text{V/V}$
			6	18		18	57		57	180		
Large-Signal Voltage Gain	$A_{VO}$	$V_+ = 5\text{ V}$ , $V_- = 0\text{ V}$ , $R_L = 100\text{ k}\Omega$ , $1\text{ V} \leq V_O \leq 3.5\text{ V}$ $V_S = \pm 15\text{ V}$ , $R_L = 25\text{ k}\Omega$ $V_O = \pm 10\text{ V}$	500	1,000		500	800		300	500		V/mV
			1,000	2,000		1,000	2,000		800	1,600		V/mV
Output Voltage Swing	$V_O$	$V_+ = 5\text{ V}$ , $V_- = 0\text{ V}$ $R_L = 10\text{ k}\Omega$ $V_S = \pm 15\text{ V}$ , $R_L = 25\text{ k}\Omega$	0.7/4			0.7/4			0.8/4			V
			$\pm 14$			$\pm 14$			$\pm 14$			V
Slew Rate*	SR	$R_L = 25\text{ k}\Omega$		0.05			0.05			0.05		V/ $\mu\text{s}$
Bandwidth	BW	$A_{VCL} = 1$ , $R_L = 25\text{ k}\Omega$		200			200			200		kHz
Supply Current (Both Amplifiers)	$I_{SY}$	$V_S = \pm 2.5\text{ V}$ , No Load $V_S = \pm 15\text{ V}$ , No Load	100	115		115	125		125	135		$\mu\text{A}$
			140	170		150	190		205	220		$\mu\text{A}$

\*Sample tested.

## ELECTRICAL CHARACTERISTICS ( $V_S = \pm 2.5\text{ V}$ to $\pm 15\text{ V}$ , $-55^\circ\text{C} \leq T_A \leq +125^\circ\text{C}$ for OP220A/C, $-25^\circ\text{C} \leq T_A \leq +85^\circ\text{C}$ for OP220E/F, $-40^\circ\text{C} \leq T_A \leq +85^\circ\text{C}$ for OP220G unless otherwise noted.)

Parameter	Symbol	Conditions	OP220A/E			OP220F			OP220C/G			Unit
			Min	Typ	Max	Min	Typ	Max	Min	Typ	Max	
Input Offset Voltage Drift*	$TCV_{OS}$	$V_S = \pm 15\text{ V}$		0.75	1.5		1.2	2		2	3	$\mu\text{V}/^\circ\text{C}$
Input Offset Voltage	$V_{OS}$			200	300		400	500		1,000	1,300	$\mu\text{V}$
Input Offset Current	$I_{OS}$	$V_{CM} = 0$		0.5	2		0.6	2.5		0.6	5	nA
Input Bias Current	$I_B$	$V_{CM} = 0$		12	25		13	30		14	40	nA
Input Voltage Range	IVR	$V_+ = 5\text{ V}$ , $V_- = 0\text{ V}$ $V_S = \pm 15\text{ V}$	0/3.2 -15/+13.2			0/3.2 -15/+13.2			0/3.2 -15/+13.2			V V
Common-Mode Rejection Ratio	CMRR	$V_+ = 5\text{ V}$ , $V_- = 0\text{ V}$ $0\text{ V} \leq V_{CM} \leq 3.2\text{ V}$ $V_S = \pm 15\text{ V}$ $-15\text{ V} \leq V_{CM} \leq +13.2\text{ V}$	86	90		80	85		70	80		dB
			90	95		85	90		75	85		dB
Power Supply Rejection Ratio	PSRR	$V_S = \pm 2.5\text{ V}$ to $\pm 15\text{ V}$ , $V_- = 0\text{ V}$ , $V_+ = 5\text{ V}$ to $30\text{ V}$	6	18		18	57		57	180		$\mu\text{V/V}$ $\mu\text{V/V}$
			10	32		32	100		100	320		
Large-Signal Voltage Gain	$A_{VO}$	$V_S = \pm 15\text{ V}$ , $R_L = 50\text{ k}\Omega$ $V_O = \pm 10\text{ V}$	500	1,000		500	800		400	500		V/mV
Output Voltage Swing	$V_O$	$V_+ = 5\text{ V}$ , $V_- = 0\text{ V}$ $R_L = 20\text{ k}\Omega$ $V_S = \pm 15\text{ V}$ , $R_L = 50\text{ k}\Omega$	0.9/3.8			0.9/3.8			1.0/3.8			V
			$\pm 13.6$			$\pm 13.6$			$\pm 13.6$			V
Supply Current (Both Amplifiers)	$I_{SY}$	$V_S = \pm 2.5\text{ V}$ , No Load $V_S = \pm 15\text{ V}$ , No Load	135	170		155	185		170	210		$\mu\text{A}$
			190	250		200	280		275	330		$\mu\text{A}$

\*Sample tested.

## MATCHING CHARACTERISTICS (@ $V_S = \pm 15\text{ V}$ , $T_A = 25^\circ\text{C}$ , unless otherwise noted.)

Parameter	Symbol	Conditions	OP220A/E			OP220F			OP220C/G			Unit
			Min	Typ	Max	Min	Typ	Max	Min	Typ	Max	
Input Offset Voltage Match	$\Delta V_{OS}$			150	300		250	500		300	800	$\mu\text{V}$
Average Noninverting Bias Current	$I_{B+}$	$V_{CM} = 0$		10	20		15	25		20	30	nA
Noninverting Offset Current	$I_{OS+}$	$V_{CM} = 0$		0.7	1.5		1	2		1.4	2.5	nA
Common-Mode Rejection Ratio Match <sup>1</sup>	$\Delta\text{CMRR}$	$V_{CM} = -15\text{ V to }+13.5\text{ V}$	92	100		87	95		72	85		dB
Power Supply Rejection Ratio Match <sup>2</sup>	$\Delta\text{PSRR}$	$V_S = \pm 2.5\text{ V to } \pm 15\text{ V}$ ,		6	14		18	44		57	140	$\mu\text{V/V}$

## NOTES

<sup>1</sup> $\Delta\text{CMRR}$  is  $20 \log_{10} V_{CM}/\Delta\text{CME}$ , where  $V_{CM}$  is the voltage applied to both noninverting inputs and  $\Delta\text{CME}$  is the difference in common-mode input-referred error.

<sup>2</sup> $\Delta\text{PSRR}$  is  $\frac{\text{Input Referred Differential Error}}{\Delta V_S}$ .

<sup>3</sup>Sample tested.

## MATCHING CHARACTERISTICS ( $V_S = \pm 15\text{ V}$ , $-55^\circ\text{C} \leq T_A \leq +125^\circ\text{C}$ for OP220A/C, $-25^\circ\text{C} \leq T_A \leq +85^\circ\text{C}$ for OP220E/F, $-40^\circ\text{C} \leq T_A \leq +85^\circ\text{C}$ for OP220G unless otherwise noted. Grades E, F are sample tested.)

Parameter	Symbol	Conditions	OP220A/E			OP220F			OP220C/G			Unit
			Min	Typ	Max	Min	Typ	Max	Min	Typ	Max	
Input Offset Voltage Match	$\Delta V_{OS}$			250	500		400	800		800	1,800	$\mu\text{V}$
Input Offset Voltage Tracking <sup>1</sup>	$\text{TC}\Delta V_{OS}$			1	2		1.5	3		1.5	5	$\mu\text{V}/^\circ\text{C}$
Average Noninverting Bias Current	$I_{B+}$	$V_{CM} = 0$		10	25		15	30		22	40	nA
Average Drift of Noninverting Bias Current <sup>1</sup>	$\text{TC}I_{B+}$	$V_{CM} = 0$		15	25		15	30		30	50	$\text{pA}/^\circ\text{C}$
Noninverting Offset Current	$I_{OS+}$	$V_{CM} = 0$		0.7	2		1	2.5		2.5	5	nA
Average Drift of Noninverting Offset Current <sup>1</sup>	$\text{TC}I_{OS+}$	$V_{CM} = 0$		7	15		12	22.5		15	30	$\text{pA}/^\circ\text{C}$
Common-Mode Rejection Ratio Match <sup>2</sup>	$\Delta\text{CMRR}$	$V_{CM} = -15\text{ V to }+13\text{ V}$	87	96		82	96		72	80		dB
Power Supply Rejection Ratio Match <sup>3</sup>	$\Delta\text{PSRR}$	$V_S = \pm 2.5\text{ V to } \pm 15\text{ V}$ ,		10	26		30	78		57	250	$\mu\text{V/V}$

## NOTES

<sup>1</sup>Sample tested.

<sup>2</sup> $\Delta\text{CMRR}$  is  $20 \log_{10} V_{CM}/\Delta\text{CME}$ , where  $V_{CM}$  is the voltage applied to both noninverting inputs and  $\Delta\text{CME}$  is the difference in common-mode input-referred error.

<sup>3</sup> $\Delta\text{PSRR}$  is  $\frac{\text{Input Referred Differential Error}}{\Delta V_S}$ .

## TYPICAL ELECTRICAL CHARACTERISTICS (@ $V_S = \pm 15\text{ V}$ , $T_A = 25^\circ\text{C}$ , unless otherwise noted.)

Parameter	Symbol	Conditions	OP220N Typical	Unit
Average Input Offset Voltage Drift	$\text{TC}V_{OS}$		1.5	$\mu\text{V}/^\circ\text{C}$
Large-Signal Voltage Gain	$A_{VO}$	$R_L = 25\text{ k}\Omega$	2000	V/mV

# OP220–SPECIFICATIONS

## ABSOLUTE MAXIMUM RATINGS\*

Supply Voltage	±18 V
Differential Input Voltage	30 V or Supply Voltage
Input Voltage	Supply Voltage
Output Short-Circuit Duration	Indefinite
Storage Temperature Range	-65°C to +150°C
Junction Temperature (T <sub>J</sub> )	-65°C to +150°C
Operating Temperature Range	
OP220A/OP220C	-55°C to +125°C
OP220E/OP220F	-25°C to +85°C
OP220G	-40°C to +85°C
Lead Temperature Range (Soldering, 60 sec)	300°C

## NOTES

\*Absolute Maximum Ratings apply to packaged parts, unless otherwise noted.

## DIE CHARACTERISTICS

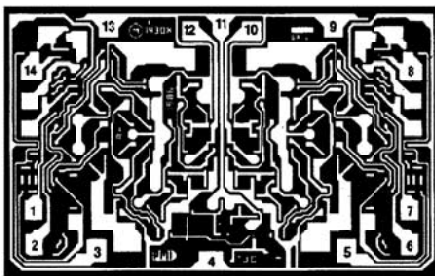

1. INVERTING INPUT (A)
2. NONINVERTING INPUT (A)
3. BALANCE (A)
4. V<sub>-</sub>
5. BALANCE (B)
6. NONINVERTING INPUT (B)
7. INVERTING INPUT (B)
8. BALANCE (B)
9. V<sub>+</sub>
10. OUT (B)
11. V<sub>+</sub>
12. OUT (A)
13. V<sub>+</sub>
14. BALANCE (A)

DIE SIZE 0.097 INCH × 0.063 INCH, 6111 SQ. MILS  
(2.464 mm × 1.600 mm, 3.94 SQ. mm)

NOTE: ALL V<sub>+</sub> PADS ARE INTERNALLY CONNECTED

Package Type	θ <sub>JA</sub> *	θ <sub>JC</sub>	Unit
8-Lead Hermetic DIP (Q)	148	16	°C/W
8-Lead Plastic DIP (N)	103	43	°C/W
8-Lead SOL (RN)	158	43	°C/W
TO-99 (H)	150	18	°C/W

\*θ<sub>JA</sub> is specified for worst-case mounting conditions, i.e., θ<sub>JA</sub> is specified for device in socket for Cerdip and PDIP packages; θ<sub>JA</sub> is specified for device soldered to printed circuit board for SO packages.

## ORDERING GUIDE

T <sub>A</sub> = 25°C V <sub>OS</sub> MAX (mV)	Package Options			Operating Temperature Range
	CERDIP	Plastic	TO-99	
150	OP220AZ*			MIL
150	OP220EZ*			IND
300	OP220FZ*			IND
750		OP220CJ*	MIL	
750	OP220GZ*	OP220GP*		XIND
750		OP220GS		XIND

For military processed devices, please refer to the Mil Standard Data Sheet

OP220AJ/883\*.

\*Not for new design. Obsolete April 2002.

## WAFER TEST LIMITS (@ V<sub>S</sub> = ±2.5 V, to ±15 V, T<sub>A</sub> = 25°C, unless otherwise noted.)

Parameter	Symbol	Conditions	OP220N Limit	Unit
Input Offset Voltage	V <sub>OS</sub>		200	µV Max
Input Offset Voltage Match	ΔV <sub>OS</sub>		300	µV Max
Input Offset Current	I <sub>OS</sub>	V <sub>CM</sub> = 0	2	nA Max
Input Bias Current	I <sub>B</sub>	V <sub>CM</sub> = 0	25	nA Max
Input Voltage Range	IVR	V <sub>S</sub> = ±15 V	-15/13.5	V Min
Common-Mode Rejection Ratio	CMRR	V <sub>-</sub> = 0 V, V <sub>+</sub> = 5 V, 0 V ≤ V <sub>CM</sub> ≤ 3.5 V -15 V ≤ V <sub>CM</sub> ≤ 13.5 V, V <sub>S</sub> = ±15 V	88 93	dB Min
Power Supply Rejection Ratio	PSRR	V <sub>S</sub> = ±2.5 V to ±15 V V <sub>-</sub> = 0 V, V <sub>+</sub> = 5 V to 30 V	12.5 22.5	µV/V Max
Large-Signal Voltage Gain	A <sub>VO</sub>	R <sub>L</sub> = 25 kΩ, V <sub>S</sub> = ±15 V V <sub>O</sub> = ±10 V	1000	V/mV Min
Output Voltage Swing	V <sub>O</sub>	V <sub>+</sub> = 5 V, V <sub>-</sub> = 0 V, R <sub>L</sub> = 10 kΩ V <sub>S</sub> = ±15 V, R <sub>L</sub> = 25 kΩ	0.7/4 ±14	V Min
Supply Current (Both Amplifiers)	I <sub>SY</sub>	V <sub>S</sub> = ±2.5 V, No Load V <sub>S</sub> = ±15 V, No Load	125 190	µA Max

## NOTE

Electrical tests are performed at wafer probe to the limits shown. Due to variations in assembly methods and normal yield loss, yield after packing is not guaranteed for standard product dice. Consult factory to negotiate specifications based on die lot qualification through sample lot assembly and testing.

# Typical Performance Characteristics-OP220

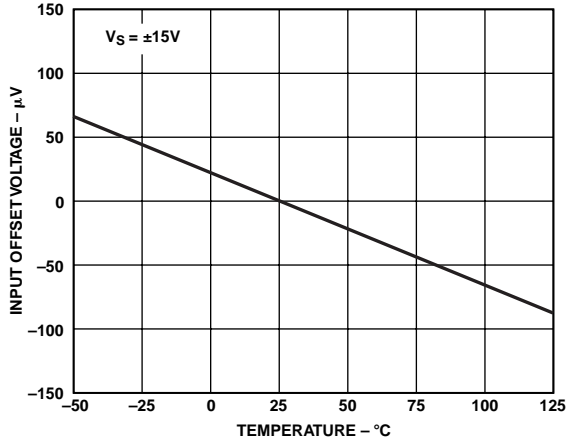

TPC 1. Normalized Offset Voltage vs. Temperature

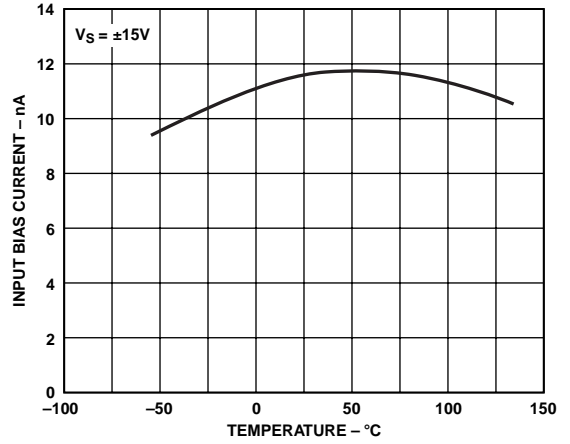

TPC 4. Input Bias Current vs. Temperature

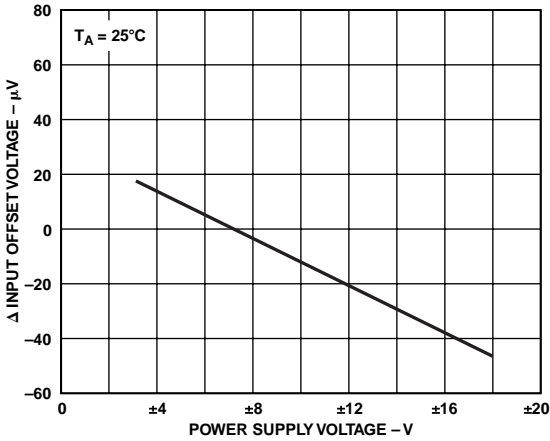

TPC 2. Input Offset Voltage vs. Power Supply Voltage

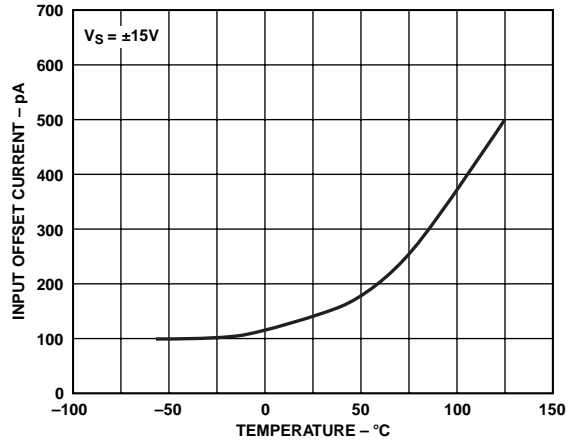

TPC 5. Input Offset Current vs. Temperature

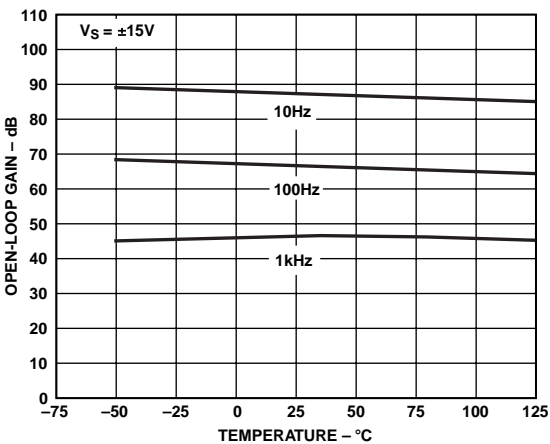

TPC 3. Open-Loop Gain vs. Temperature

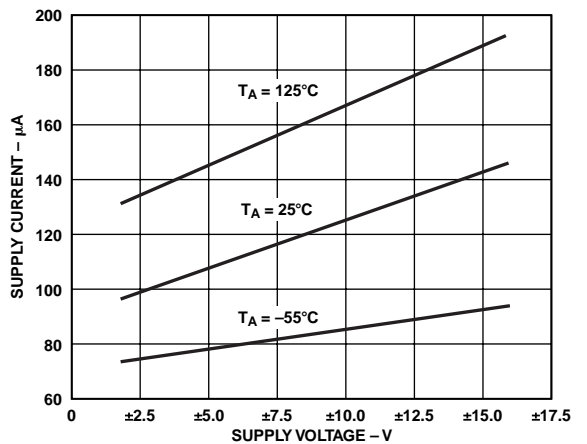

TPC 6. Supply Current vs. Supply Voltage

# OP220

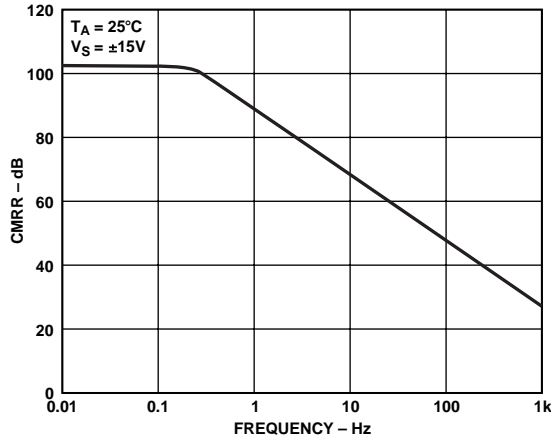

TPC 7. CMRR vs. Frequency

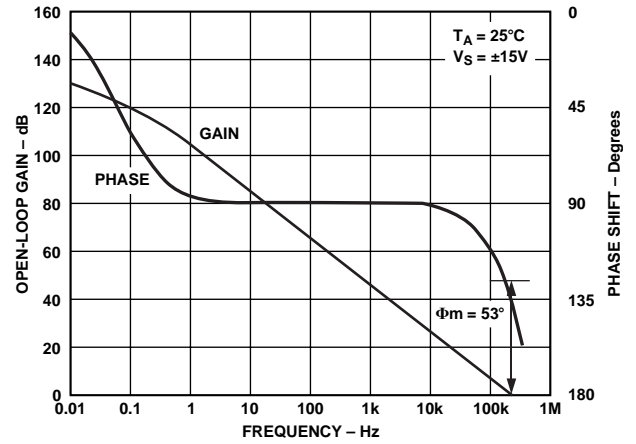

TPC 10. Open-Loop Voltage Gain and Phase vs. Frequency

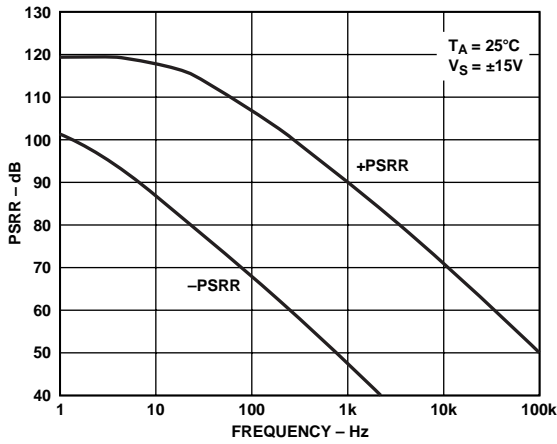

TPC 8. PSRR vs. Frequency

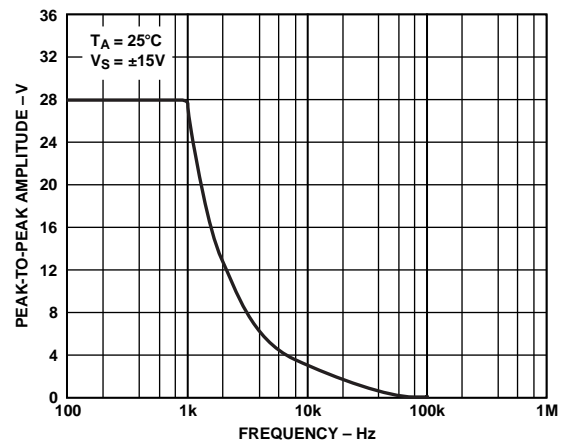

TPC 11. Maximum Output Swing vs. Frequency

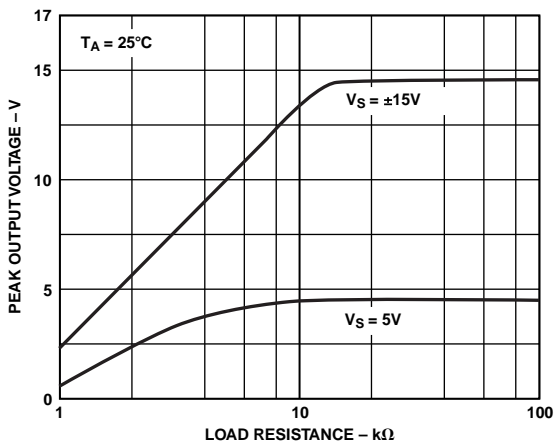

TPC 9. Maximum Output Voltage vs. Load Resistance

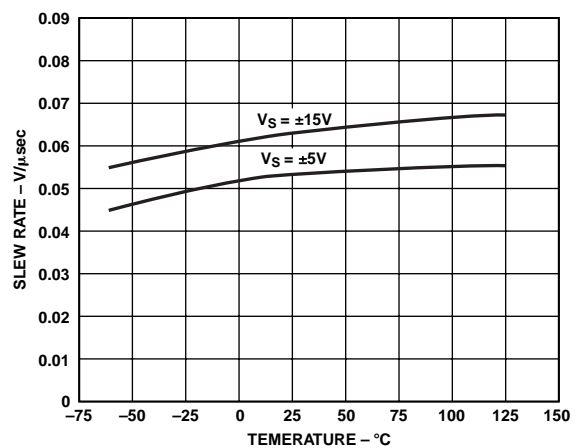

TPC 12. Slew Rate vs. Temperature

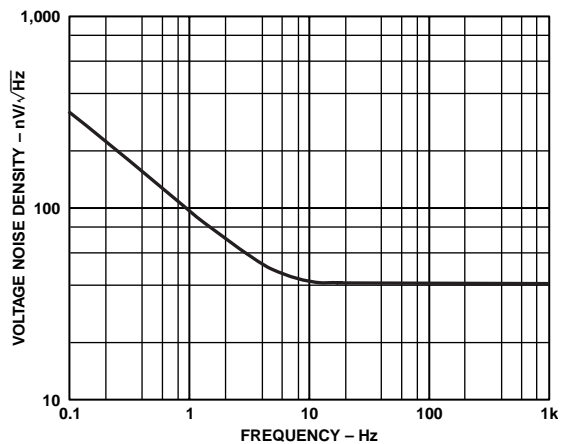

TPC 13. Voltage Noise Density vs. Frequency

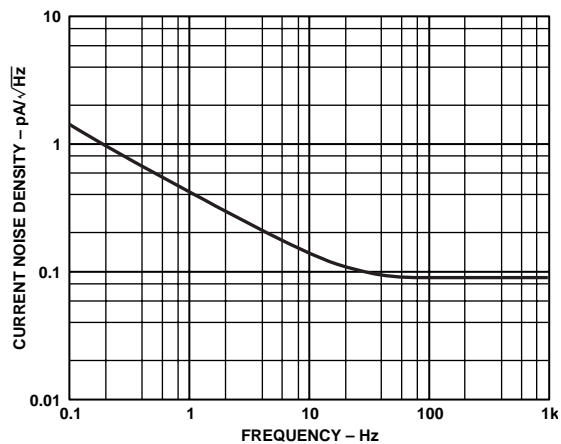

TPC 14. Noise Density vs. Frequency

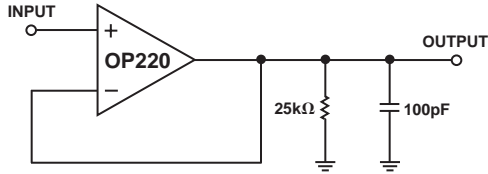
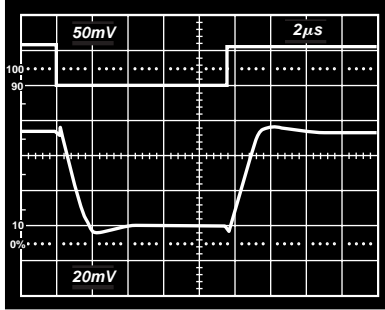

Figure 2. Small-Signal Transient Response

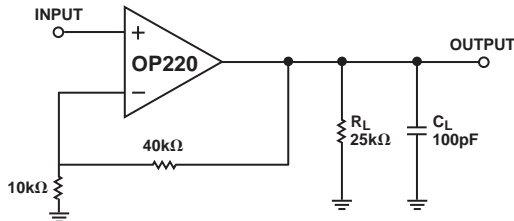
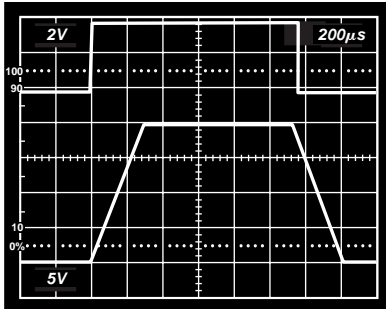

Figure 3. Large-Signal Transient Response

**INSTRUMENTATION AMPLIFIER APPLICATIONS OF THE OP220**

**Two Op Amp Configuration**

The excellent input characteristics of the OP220 make it ideal for use in instrumentation amplifier configurations where low-level differential signals are to be amplified. The low-noise, low input offsets, low drift, and high gain combined with excellent CMRR provide the characteristics needed for high-performance instrumentation amplifiers. In addition, the power supply current drain is very low.

The circuit of Figure 4 is recommended for applications where the common-mode input range is relatively low and differential gain will be in the range of 10 to 1,000. This two op amp instrumentation amplifier features independent adjustment of common-mode rejection and differential gain. Input impedance is very high since both inputs are applied to noninverting op amp inputs.

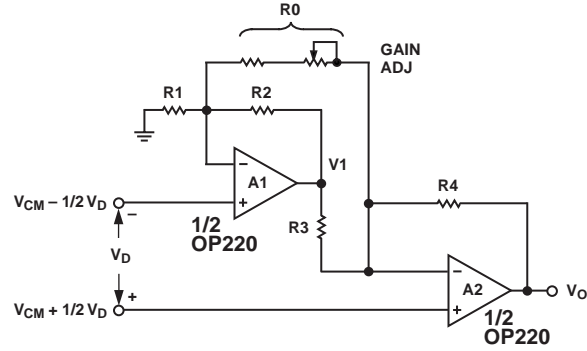

$$V_O = \frac{R4}{R3} \left[ 1 + \frac{1}{2} \left( \frac{R2}{R1} + \frac{R3}{R4} \right) + \frac{R2 + R3}{R0} \right] V_D + \frac{R4}{R3} \left( \frac{R3}{R4} - \frac{R2}{R1} \right) V_{CM}$$

If  $R1 = R2 = R3 = R4$ , then  $V_O = 2 \left( 1 + \frac{R1}{R0} \right) V_D$

Figure 4. Two Op Amp Instrumentation Amplifier Configuration

The input voltages are represented as a common-mode input  $V_{CM}$  plus a differential input  $V_D$ . The ratio  $R3/R4$  is made equal to the ratio  $R2/R1$ , to reject the common-mode input  $V_{CM}$ . The differential signal  $V_D$  is then amplified according to:

$$V_O = \frac{R4}{R3} \left( 1 + \frac{R3}{R4} + \frac{R2 + R3}{R0} \right) V_D, \text{ where } \frac{R3}{R4} = \frac{R2}{R1}$$

Note that gain can be independently varied by adjusting  $R_0$ . From considerations of dynamic range, resistor tempco matching, and matching of amplifier response, it is generally best to make  $R_X, R_2, R_3$ , and  $R_4$  approximately equal. Designating  $R_1, R_2, R_3$ , and  $R_4$  as  $R_N$  allows the output equation to be further simplified:

$$V_O = 2 \left( 1 + \frac{R_N}{R_0} \right) V_D, \text{ where } R_N = R_1 = R_2 = R_3 = R_4$$

Dynamic range is limited by A1 as well as A2; the output of A1 is:

$$V1 = - \left( 1 + \frac{R_N}{R_0} \right) V_D + 2 V_{CM}$$

If the instrumentation amplifier were designed for a gain of 10 and maximum  $V_D$  of  $\pm 1$  V, then  $R_N/R_0$  would need to be four and  $V_O$  would be a maximum of  $\pm 10$  V. Amplifier A1 would have a maximum output of  $\pm 5$  V plus  $2 V_{CM}$ , thus a limit of  $\pm 10$  V on the output of A1 would imply a limit of  $\pm 2.5$  V on  $V_{CM}$ .

A nominal value of 100 kΩ for  $R_N$  is suitable for most applications. A range of 200 Ω to 25 kΩ for  $R_0$  will then provide a gain range of 10 to 1,000. The current through  $R_0$  is  $V_D/R_0$ , so the amplifiers must supply  $\pm 10$  mV/200 Ω when the gain is at the maximum value of 1,000 and  $V_D$  is at  $\pm 10$  mV.

Rejecting common-mode inputs is most important in accurately amplifying low-level differential signals. Two factors determine the CMR of this instrumentation amplifier configuration (assuming infinite gain):

1. CMRR of the op amps
2. Matching of the resistor network ( $R3/R4 = R2/R1$ )



In this instrumentation amplifier configuration, error due to CMRR effect is directly proportional to the differential CMRR of the op amps. For the OP220A/E, this combined CMRR is a minimum of 98 dB. A combined CMRR value of 100 dB and common-mode input range of  $\pm 2.5$  V indicates a peak input-referred error of only  $\pm 25$   $\mu$ V.

Resistor matching is the other factor affecting CMRR. Defining  $A_D$  as the differential gain of the instrumentation amplifier and assuming that  $R_1$ ,  $R_2$ ,  $R_3$  and  $R_4$  are approximately equal ( $R_N$  will be the nominal value), then CMRR will be approximately  $A_D$  divided by  $4\Delta R/R_N$ . CMRR at differential gain of 100 would be 88 dB with resistor matching of 0.1%. Trimming  $R_1$  to make the ratio  $R_3/R_4$  equal to  $R_2/R_1$  will directly raise the CMRR until it is limited by linearity and resistor stability considerations.

The high open-loop gain of the OP220 is very important in achieving high accuracy in the two-op-amp instrumentation amplifier configuration. Gain error can be approximated by:

$$\text{Gain Error} = \frac{1}{1 + \frac{A_D}{A_{02}}}, \frac{A_D}{2A_{01}A_{02}} < 1$$

where  $A_D$  is the instrumentation amplifier differential gain and  $A_{02}$  is the open-loop gain of op amp A2. This analysis assumes equal values of  $R_1$ ,  $R_2$ ,  $R_3$ , and  $R_4$ . For example, consider an OP220 with  $A_{02}$  of 700 V/mV. If the differential gain  $A_D$  were set to 700, the gain error would be 1/1.001 which is approximately 0.1%.

Another effect of finite op amp gain is undesired feedthrough of common-mode input. Defining  $A_{01}$  as the open-loop gain of op amp A1, then the common-mode error (CME) at the output due to this effect will be approximately:

$$\text{CME} = \frac{2A_D}{1 + \frac{A_D}{A_{01}}} \frac{1}{A_{01}} V_{CM}$$

For  $A_D/A_{01} < 1$ , this simplifies to  $(2A_D/A_{01}) \times V_{CM}$ . If the op amp gain is 700 V/mV,  $V_{CM}$  is 2.5 V, and  $A_D$  is set to 700, then the error at the output due to this effect will be approximately 5 mV.

The OP220 offers a unique combination of excellent dc performance, wide input range, and low supply current drain that is particularly attractive for instrumentation amplifier design.

### THREE OP AMP CONFIGURATION

A three op amp instrumentation amplifier configuration using the OP220 and OP777 is recommended for applications requiring high accuracy over a wide gain range. This circuit provides excellent CMR over a wide input range. As with the two op amp instrumentation amplifier circuits, tight matching of the two op amps provides a real boost in performance.

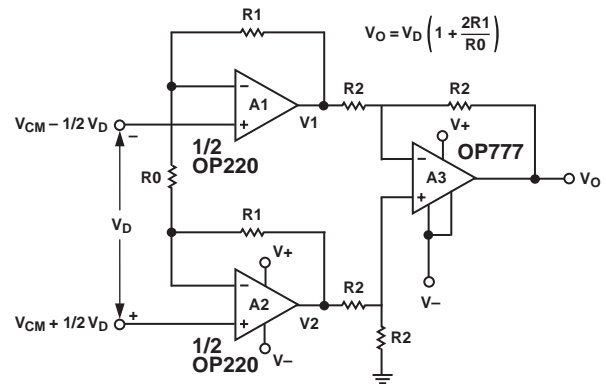

Figure 5. Three Op Amp Instrumentation Amplifier Using OP220 and OP777

A simplified schematic is shown in Figure 2. The input stage (A1 and A2) serves to amplify the differential input  $V_D$  without amplifying the common-mode voltage  $V_{CM}$ . The output stage then rejects the common-mode input. With ideal op amps and no resistor matching errors, the outputs of each amplifier will be:

$$V_1 = -\left(1 + \frac{2R_1}{R_O}\right) \frac{V_D}{2} + V_{CM}$$

$$V_2 = \left(1 + \frac{2R_1}{R_O}\right) \frac{V_D}{2} + V_{CM}$$

$$V_O = V_2 - V_1 = \left(1 + \frac{2R_1}{R_O}\right) V_D$$

$$V_O = A_D V_D$$

The differential gain  $A_D$  is  $1 + 2R_1/R_O$  and the common-mode input  $V_{CM}$  is rejected.

This three op amp instrumentation amplifier configuration using an OP220 at the input and an OP777 at the output provides excellent performance over a wide gain range with very low power consumption. A gain range of 1 to 2,000 is practical and CMR of over 120 dB is readily achievable.

## OUTLINE DIMENSIONS

### 8-Lead Ceramic DIP – Glass Hermetic Seal [CERDIP] (Q-8)

Dimensions shown in inches and (millimeters)

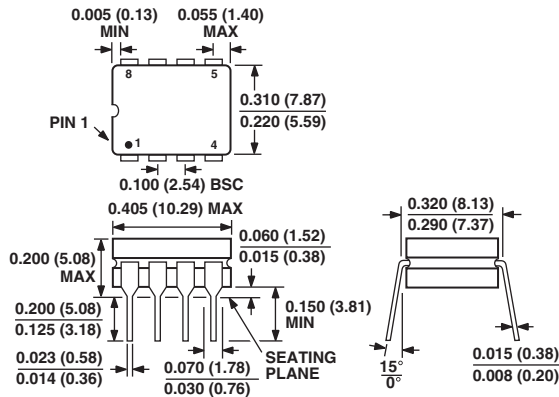

CONTROLLING DIMENSIONS ARE IN INCH; MILLIMETERS DIMENSIONS (IN PARENTHESES) ARE ROUNDED-OFF MILLIMETER EQUIVALENTS FOR REFERENCE ONLY AND ARE NOT APPROPRIATE FOR USE IN DESIGN

### 8-Lead Standard Small Outline Package [SOIC] Narrow Body (RN-8)

Dimensions shown in millimeters and (inches)

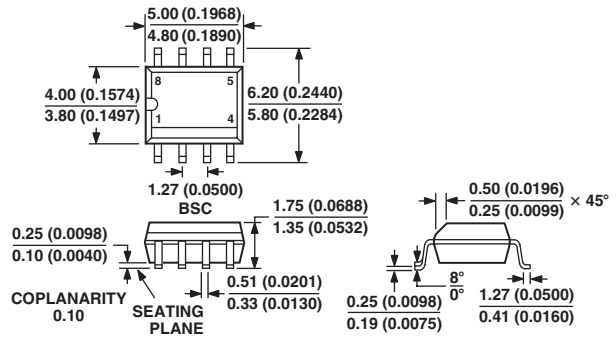

COMPLIANT TO JEDEC STANDARDS MS-012AA  
CONTROLLING DIMENSIONS ARE IN MILLIMETERS; INCH DIMENSIONS (IN PARENTHESES) ARE ROUNDED-OFF MILLIMETER EQUIVALENTS FOR REFERENCE ONLY AND ARE NOT APPROPRIATE FOR USE IN DESIGN

### 8-Lead Plastic Dual-in-Line Package [PDIP] (N-8)

Dimensions shown in inches and (millimeters)

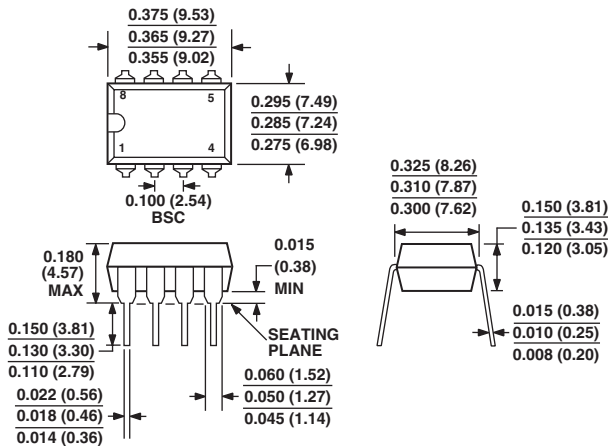

COMPLIANT TO JEDEC STANDARDS MO-095AA  
CONTROLLING DIMENSIONS ARE IN INCHES; MILLIMETERS DIMENSIONS (IN PARENTHESES)

### 8-Lead Metal Can [TO-99] (H-08)

Dimensions shown in inches and (millimeters)

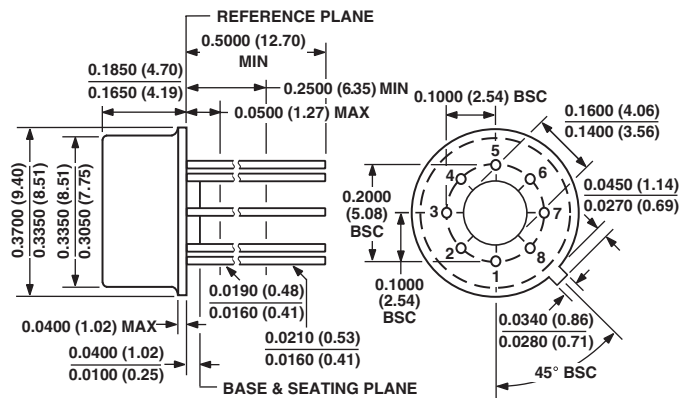

COMPLIANT TO JEDEC STANDARDS MO-002AK  
CONTROLLING DIMENSIONS ARE IN INCHES; MILLIMETERS DIMENSIONS (IN PARENTHESES) ARE ROUNDED-OFF EQUIVALENTS FOR REFERENCE ONLY AND ARE NOT APPROPRIATE FOR USE IN DESIGN

# Revision History

Location	Page
<b>10/02—Data Sheet changed from REV. 0 to REV. A.</b>	
Edits to TYPICAL ELECTRICAL CHARACTERISTICS .....	3
Edits to WAFER TEST LIMITS .....	4
Change to ORDERING GUIDE .....	4
Updated OUTLINE DIMENSIONS .....	10

